



# Discover what you're missing

Thermo Scientific Charged Aerosol Detectors

# Hidden peaks revealed

## The analyte detection challenge

No single liquid chromatography (LC) detector delivers ideal results. Often, one analyte responds more strongly than another, or may not respond at all. What is most desired is the ability to detect a wide range of analytes (universal detection) with a response that enables accurate quantitation. Charged aerosol detection is a reliable technology that will change the way you view every sample. The Charged Aerosol Detector (CAD) can detect all non-volatile, and many semi-volatile analytes, with uniform response.

With the flexibility and performance for analytical R&D, and the simplicity and reproducibility needed for manufacturing QA/QC, charged aerosol detection can be used for the analysis of pharmaceuticals (large and small molecule), biomolecules, foods and beverages, specialty chemicals, and polymers.

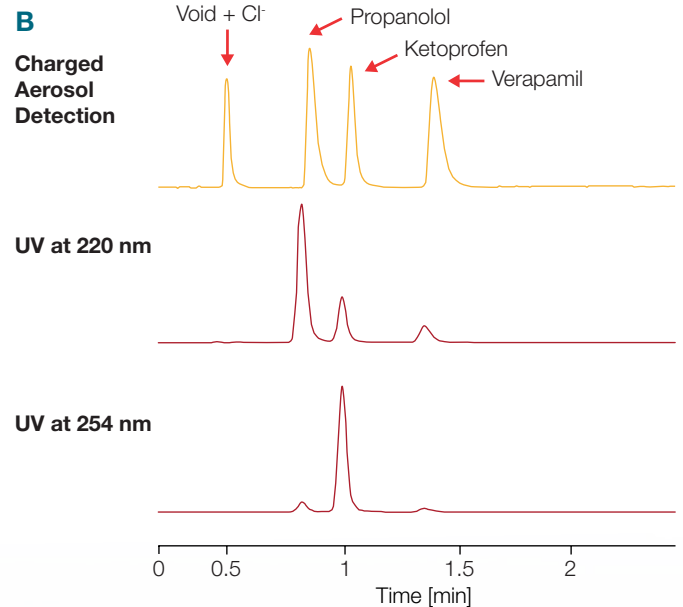
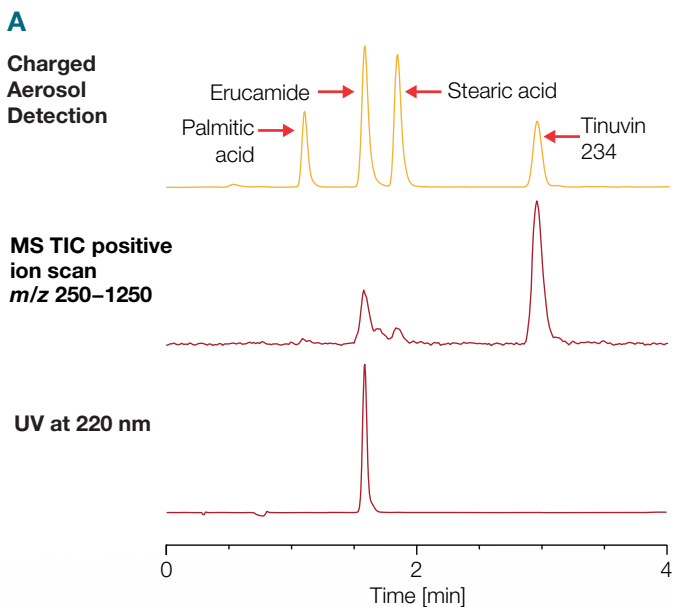

Unlike mass spectrometry (A) and UV (B), the CAD is able to measure all analytes in the sample. Mass spectrometry (MS) requires the analyte to form gas phase ions while response by a UV detector depends upon the nature of the chromophore.

# Quantify your sample

## Uniform response with charged aerosol detection

- Detector response is independent of analyte structure for all non-volatile compounds
- Excellent sensitivity coupled with wide dynamic range for unrivaled performance
- Single calibrant for quantification of multiple analytes when individual standards are not available

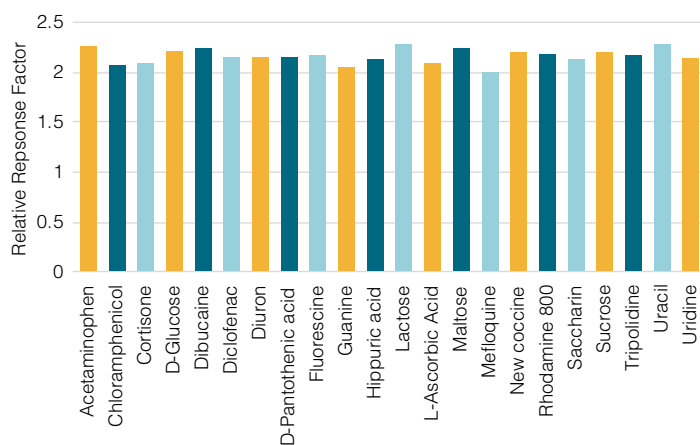

The CAD shows uniform response (<5% RSD variation) for all non-volatile analytes (0.5 µg; flow injection analysis).



*“The LC–CAD has been shown to be effective and powerful analytical tool for the determination of synthetic cannabinoids in herbal blends without their reference standards. This method can be applied to legal highs control and for risk assessment of their presence on the market.”*

*Professor Zbigniew Fijalek, Department of Bioanalysis and Drug Analysis, Warsaw Medical University*

# Understanding charged aerosol detection

Charged aerosol detection is a technique capable of measuring any non-volatile and many semi-volatile species. The technology provides more universal detection than UV, which requires a chromophore or mass spectrometry, which requires formation of gas phase ions.

With charged aerosol detection the eluent stream is nebulized, and the droplets are dried to produce analyte particles that are subsequently charged. This technology provides excellent response uniformity since particle charging is effectively independent of a compound's physicochemical properties.\*

Due to its exceptional response uniformity the CAD can be used to quantify multiple analytes using a single calibrant. Single calibrant quantitation is extremely useful when specific analyte standards are unavailable. For example, the response curve of an active pharmaceutical ingredient (API) can be used to determine levels of unknown impurities.

\* CAD response is very similar for a given absolute mass of any nonvolatile analyte. Additional correction may be needed for analytes with ionizable functional groups.

SEE TN72806 FOR ADDITIONAL DETAILS

## Three simple steps

- 1 Nebulization**  
Charged aerosol detection begins by nebulizing the eluent into droplets, which are subsequently dried into particles. The particle size increases with the amount of analyte.
- 2 Charging**  
A stream of charged nitrogen gas collides with the analyte particles. The charge is then transferred to the particles—the larger the particle, the greater the charge.
- 3 Detection**  
The charged particles are transferred to a collector where the aggregate charge is measured by a highly sensitive electrometer. This generates a signal directly proportional to the quantity of analyte present.

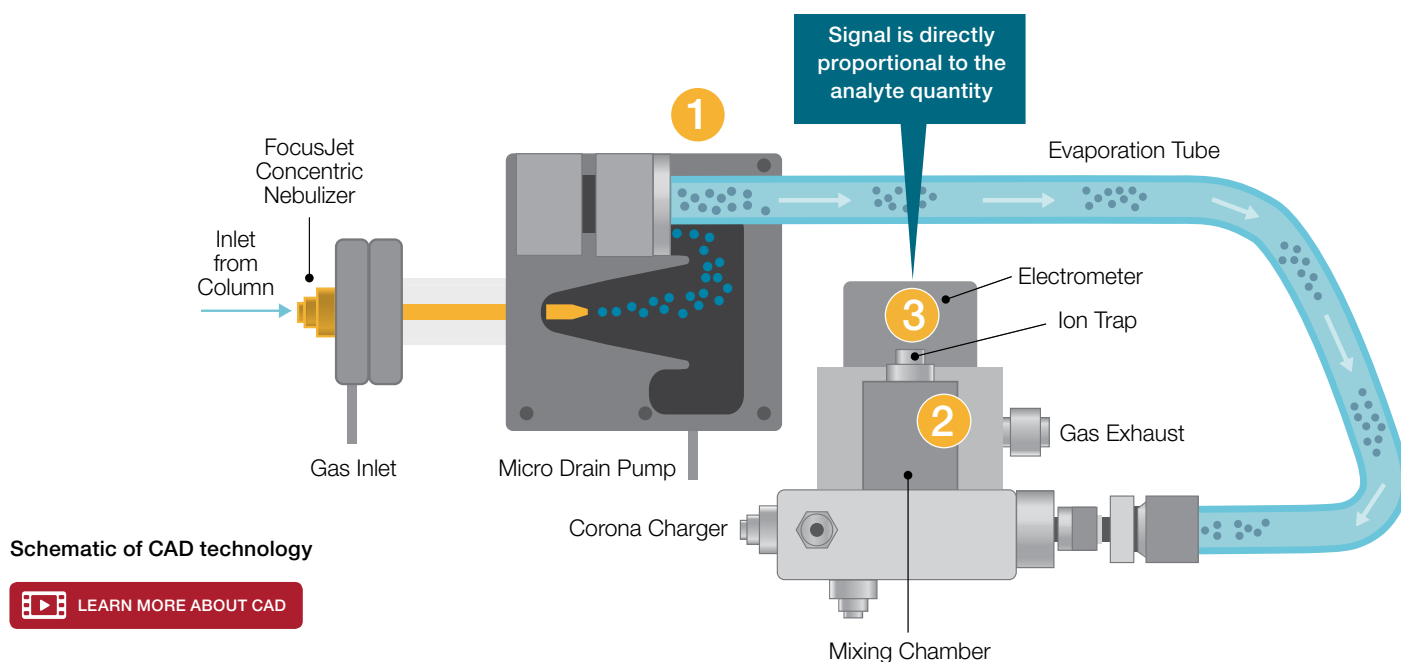

Schematic of CAD technology

LEARN MORE ABOUT CAD

# Introducing the modules

The Thermo Scientific™ Vanquish™ Charged Aerosol Detectors and Thermo Scientific™ Corona™ Veo™ Charged Aerosol Detectors provide:

- Simple, intuitive operation
- Wide linear and dynamic range
- Sub-nanogram sensitivity
- Method flexibility covering micro-flow HPLC and UHPLC applications with a single nebulizer
- Adjustable evaporation temperature to optimize signal-to-noise ratio



Vanquish Charged Aerosol Detector



Corona Veo Charged Aerosol Detector

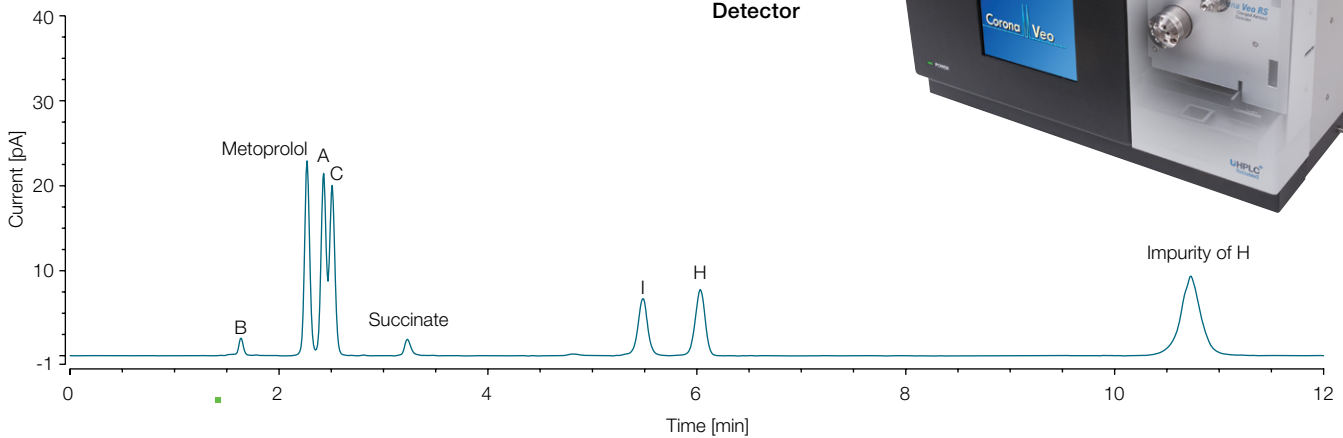

Metoprolol impurity testing using United States Pharmacopoeia method USP 41(3)

SEE AN72763 FOR GREATER DETAIL

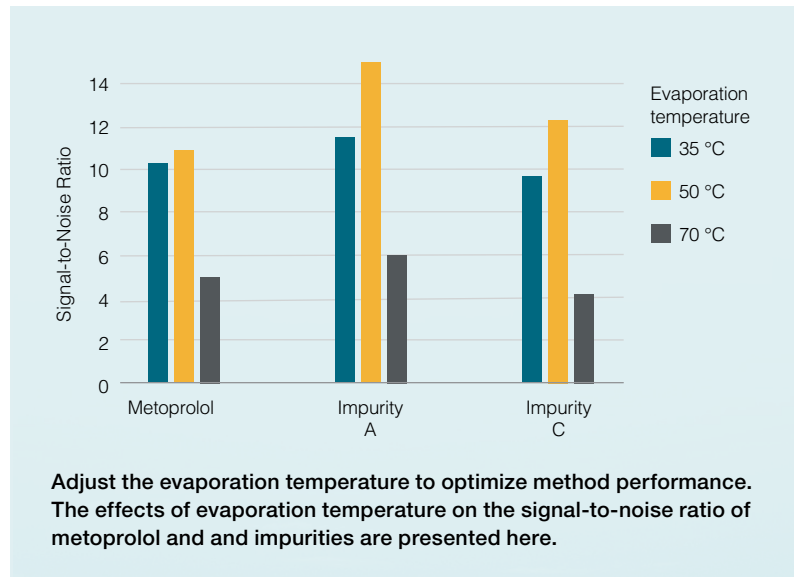

# See what you've been missing

## PHARMACEUTICAL

UHPLC-CAD is a powerful tool used throughout drug discovery and development

- Simultaneously measure anionic and cationic counterions, APIs and impurities
- Determine purity, mass balance, and the stoichiometry of drug formulations
- Speed selection of final product formulations

LEARN MORE ABOUT THE VARIOUS APPLICATION AREAS OF CHARGED AEROSOL DETECTORS

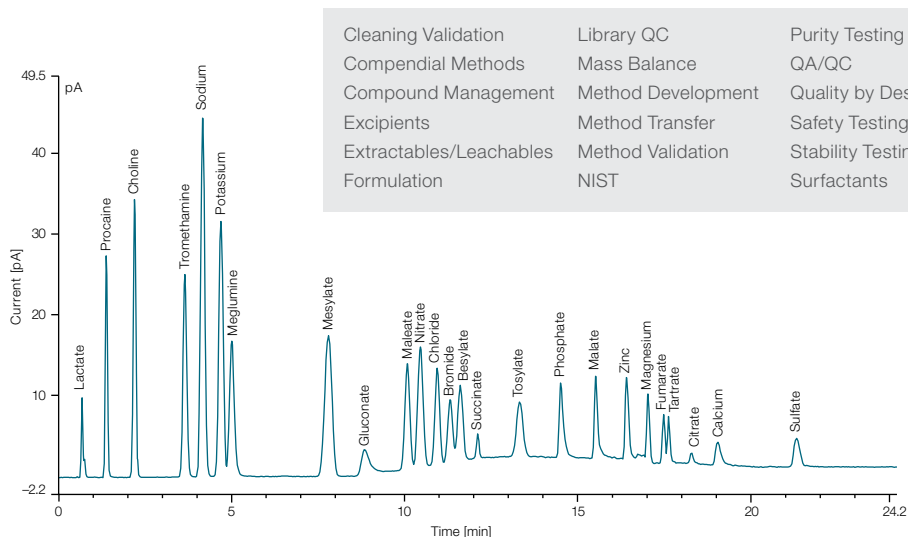

|                         |                    |                   |
|-------------------------|--------------------|-------------------|
| Cleaning Validation     | Library QC         | Purity Testing    |
| Compendial Methods      | Mass Balance       | QA/QC             |
| Compound Management     | Method Development | Quality by Design |
| Excipients              | Method Transfer    | Safety Testing    |
| Extractables/Leachables | Method Validation  | Stability Testing |
| Formulation             | NIST               | Surfactants       |

Simultaneous measurement of organic and inorganic counter-cations and counter-anions

## BIOPHARMACEUTICAL

Many proteins and active biopharmaceutical ingredients possess a chromophore allowing for conventional HPLC with UV/Vis detection. However, there are many instances where the biotherapeutic agent is UV active, but the UV-transparent excipients and critical non-chromophoric natural or chemical modifications to the compound must be detected and measured.

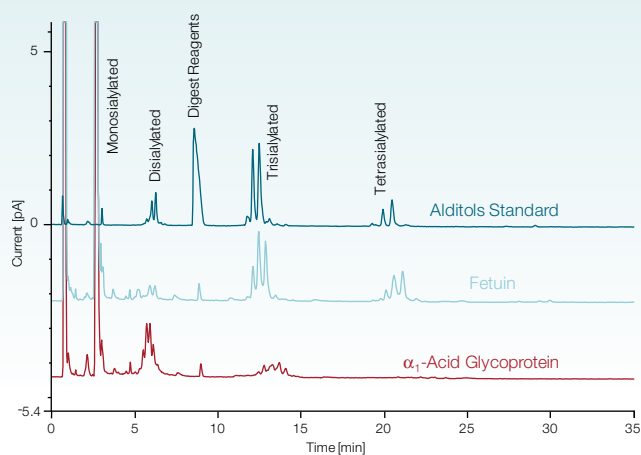

Label-free analysis of N-linked Glycans by UHPLC-CAD in PNGase F Digests

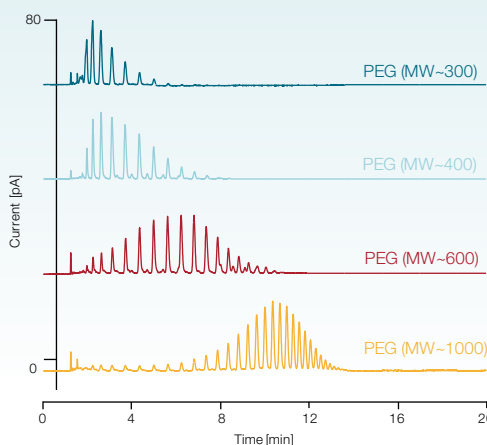

Profiling surfactants is made possible with charged aerosol detection. Quantification methods are also available.

- Adjuvants
- Biosimilars
- Conjugation
- Drug delivery
- Excipients
- Extractables/Leachables
- Formulation
- Lot-to-Lot Variability
- Liposomes
- N-linked Glycans
- O-Linked Glycans
- PEGylation
- Product Characterization
- Sialic Acid
- siRNA Delivery Vehicles
- Surfactant Quantitation and Profiling
- Tryptic Digests

LEARN MORE ABOUT BIOPHARMA

### Lipids

Lipids, including fats and oils, contain molecules with a wide variety of structural properties and are found throughout many products and industries. These compounds are traditionally difficult to characterize with conventional detection technologies. Charged aerosol detection is a powerful tool for lipid analysis due to its structure-independent response.

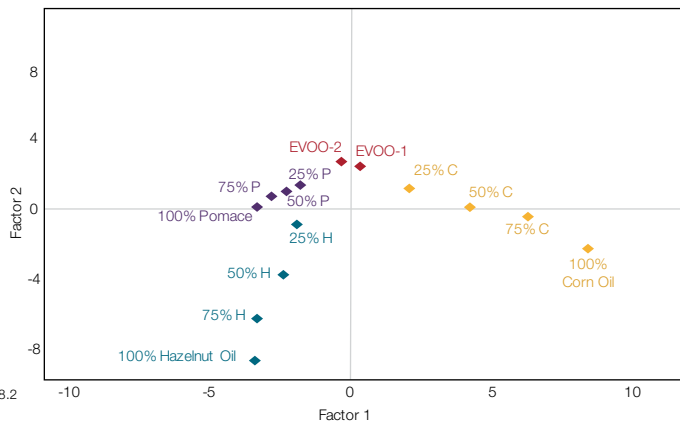
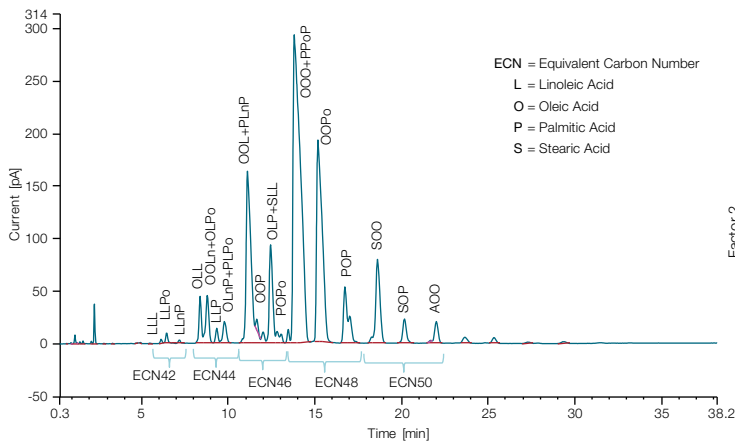

**Targeted approach: triacylglycerol measurement in pomace**

Printed with permission from Dr. Paolo Lucci and Prof. Lanfranco Conte; University of Udine, Italy

**Metabolomic approach: differences in triacylglycerol patterns measured by Principal Component Analysis can be used to determine product authenticity and adulteration. Figure shows ability to detect extra virgin olive oil (EVOO) adulteration.**

### Carbohydrates

Traditional approaches for studying sugar fingerprints in foods can be limiting, often utilizing dedicated equipment. The CAD offers the flexibility to use gradient HILIC modes of separation with the simplicity of dilute-and-shoot on any LC system.

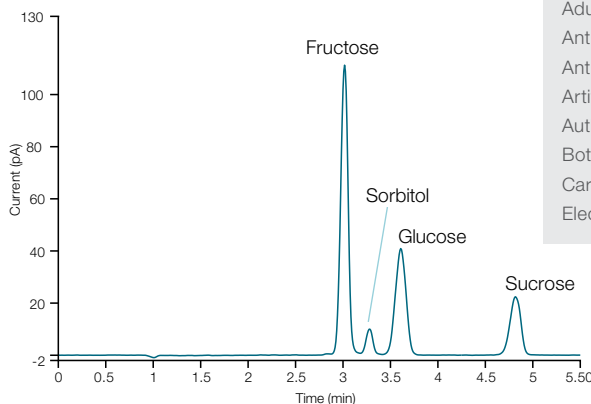

|                       |                       |
|-----------------------|-----------------------|
| Adulteration          | Emulsifiers           |
| Antifoaming Agents    | Lipids                |
| Antioxidants          | Natural Products      |
| Artificial Sweeteners | Stabilizers           |
| Authentication        | Supplements           |
| Botanicals            | Surfactants           |
| Carbohydrates         | Traditional Medicines |
| Electrolytes          | Vitamins              |

**UHPLC characterization of sugars in apple juice**

### ENVIRONMENTAL/INDUSTRIAL

### Industrial water treatment

Polyacrylic acid, a biodegradable water soluble polymer and environmentally toxic agent, is used as an anti-scaling inhibitor in circulating water systems. The low levels present in water samples are difficult to characterize using standard methods. This example shows detection by a CAD at low ppb levels.

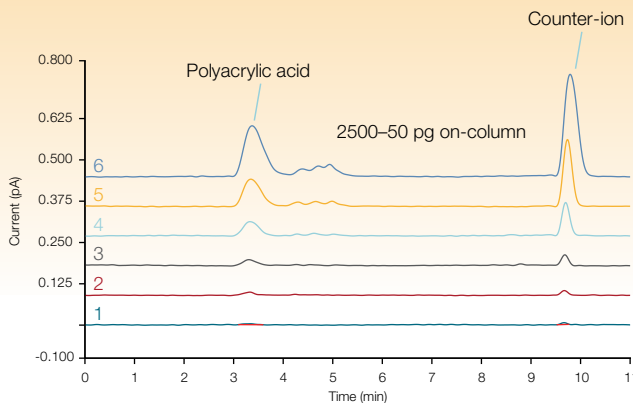

**Polyacrylic acid in cooling water**

|                        |
|------------------------|
| Algal oil              |
| Biodiesel              |
| Biomass analysis       |
| Composting             |
| Descaling agents       |
| Fracking               |
| Gas well additives     |
| Industrial polymers    |
| Ionic liquids          |
| Light stabilizers      |
| Metal working oils     |
| Oil well additives     |
| Pesticides             |
| PFCAs                  |
| Plating bath additives |
| Silicone oils          |
| Surfactants            |
| Total dissolved solids |
| Xenoestrogens          |

# Complete the installation

## The Vanquish solution

A Vanquish charged aerosol detector opens new opportunities for discovery and routine analysis. Utilize the charged aerosol detector with the increased separation speed and resolution of the Vanquish UHPLC systems for a worry-free, perfectly integrated chromatographic system.



## The UltiMate 3000 solution

Combine the Corona Veo detector with the Thermo Scientific™ UltiMate™ 3000 LC system to benefit from the extended detection capabilities for your analytical workflows and see more than before.



## Easy integration with any LC system

The Corona Veo detector is designed to integrate into any liquid chromatographic system, HPLC or UHPLC, from any manufacturer. The stackable design and rugged construction allows positioning anywhere within a system.



# Multi-detection

## Comprehensive sample analysis—more data and results in a single run

The seamless combination of complementary detectors in a single platform produces a powerful tool for the in depth characterization of complex samples. UV detection extends the range of compounds measured by the CAD to include volatile compounds. Complementary MS detection is used to confirm compound identity or for tentative identification of unknowns.

Use the multi-detector platform for:

- Thorough analysis of complex drug formulations
- Rapid evaluation of compound purity
- Quantitation and identification of impurities, degradants and contaminants
- Quantitation even when standards are unavailable using a single calibrant

All in a walk-up system with Thermo Scientific™ Chromeleon™ XPS Open Access software delivering a very streamlined interface that harnesses the full power of Chromeleon CDS.

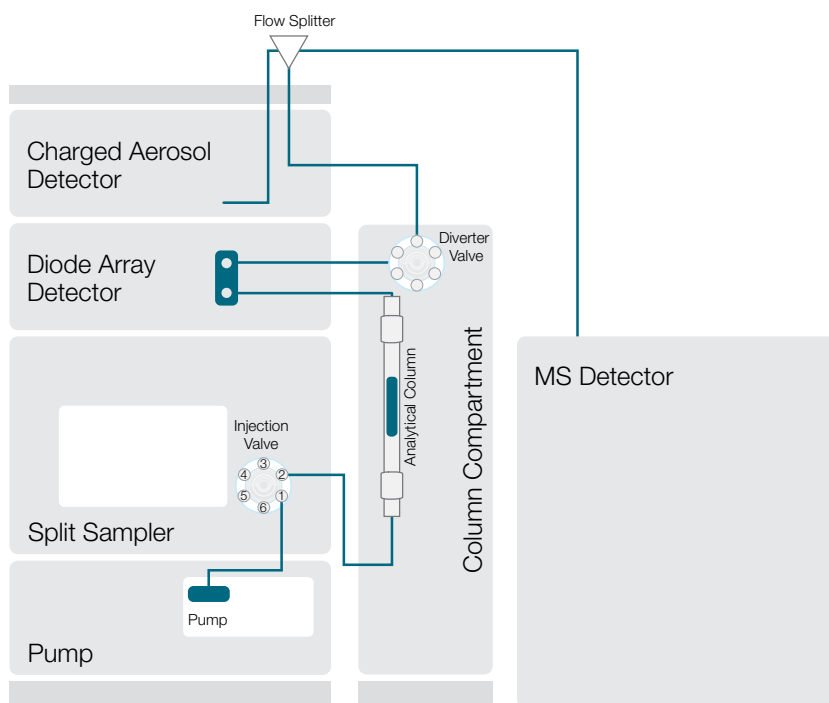

Combine UV/Vis detection, with CAD and MS detection for comprehensive quantitative sample analysis

| Analyte              | UV | CAD | MS |
|----------------------|----|-----|----|
| Phthalide            | •  |     | •  |
| Phthalaldehyde       | •  |     | •  |
| BHET                 | •  | •   | •  |
| Dimethyl phthalate   | •  |     | •  |
| Bisphenol A          | •  | •   |    |
| Butylparaben         | •  | •   | •  |
| Tinuvin P            | •  |     | •  |
| Azobenzene           | •  |     | •  |
| 2,4-di-t-butylphenol | •  |     |    |
| BHT                  | •  |     |    |
| Palmitic acid        |    | •   | •  |
| Erucamide            |    | •   | •  |
| Stearic acid         |    | •   | •  |
| Tinuvin 234          | •  | •   | •  |
| Irganox 1010         | •  | •   | •  |
| Irgafos 168          | •  | •   | •  |
| Eicosane             |    | •   |    |
| Tetracosane          |    | •   |    |

Detector response for 18 reference standards for container extractables using a multi-detector set-up for comprehensive quantitative sample analysis

[LEARN MORE DETAILS](#)

# Vanquish Duo System for Inverse Gradient

## Improve your quantitation without limitation

The response of the CAD is independent of an analyte's chemical structure, but is dependent upon the organic content of the mobile phase. Uniform response of the CAD is therefore affected by changes in solvent composition during gradient elution.

In order to use single calibrant quantitation, changes in detector response during gradient elution needs to be minimized. This is easily achieved using a secondary make up flow post column. This inverse gradient ensures that the detector "sees" a constant mobile phase composition thereby ensuring uniform response.

The Thermo Scientific™ Vanquish™ Duo UHPLC system for Inverse Gradient provides:

- Confident uniform response with gradient elution using dual pump technology
- Reliable single calibrant quantitation of knowns and unknowns independent of gradient composition
- Simplified method setup with automatic inverse gradient calculation considering all system volumes

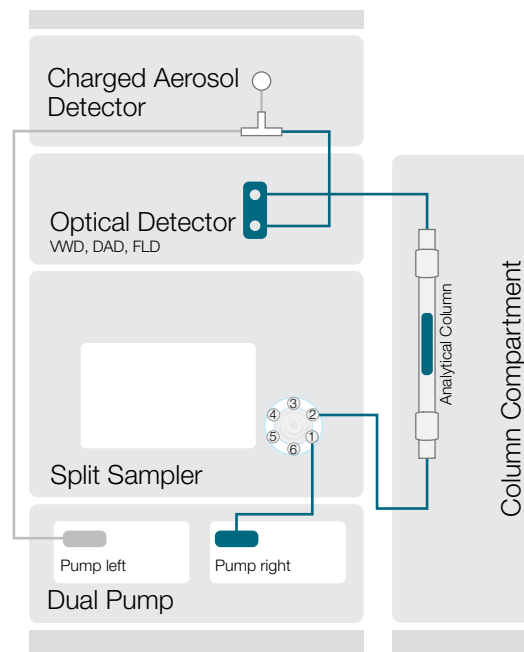

**An inverse gradient delivered by the left pump ensures that the composition of the mobile phase entering the detector remains constant thereby maintaining response uniformity**

Flow Path 1 Analytical Gradient Application 1 Reconditioning Analytical Gradient Application 1 Reconditioning

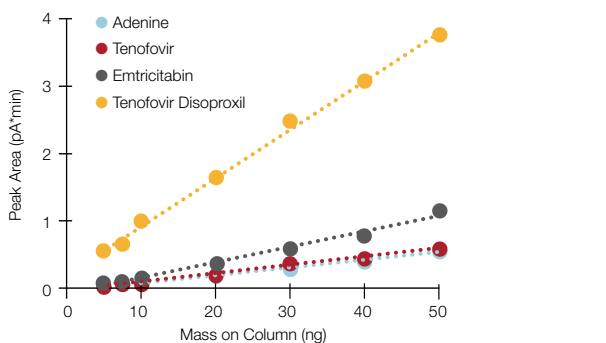

Flow Path 1 Analytical Gradient Application 1 Reconditioning Analytical Gradient Application 1 Reconditioning  
Flow Path 2

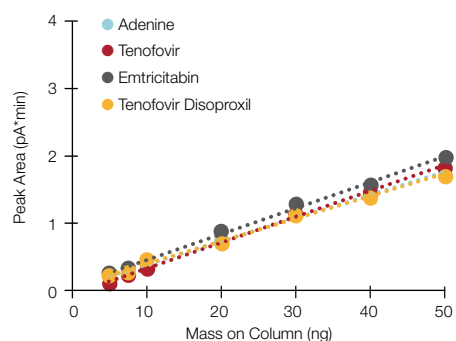

**Calibration curves for four pharmaceuticals without (left) and with (right) inverse gradient compensation (right) showing similar response curves for all compounds**

## Quantitation accuracy of unknowns using a single calibrant

This requires detector response to be independent of chemical structure:

- UV response depends on the strength of the chromophore, which in turn, is dependent on chemical structure
- CAD response for non-volatiles is independent of chemical structure but does depend upon mobile phase composition
- CAD with an inverse gradient approach results in uniform response that is ideal for single calibrant quantitation

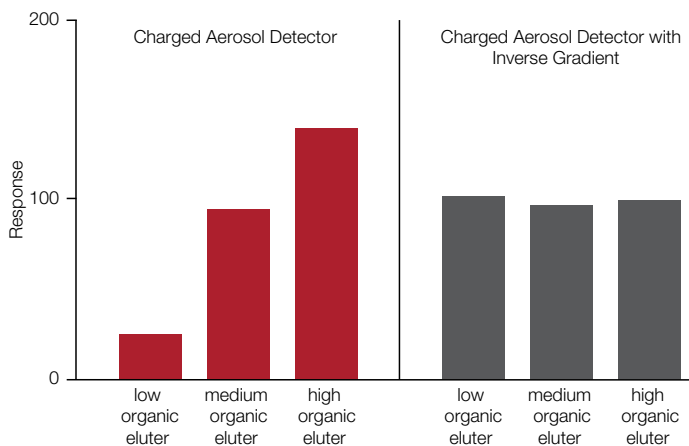

Response of the CAD is dependent upon mobile phase composition during a gradient (red bars). An inverse gradient overcomes the effect of the gradient (gray bars) on detector response.

## No extra work needed—automatic gradient implementation

Chromeleon CDS automatically identifies the inverse gradient instrument configuration and starts the dedicated method wizard. The wizard calculates and applies the inverse gradient to the second pump in the Vanquish Duo System for Inverse Gradient taking into account all internal volumes giving highest quantitation accuracy and maximized ease-of-use.

[LEARN MORE ABOUT VANQUISH DUO UHPLC](#)

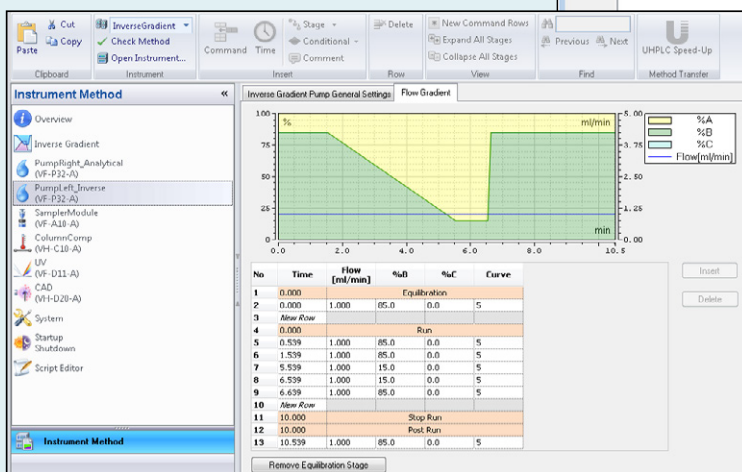
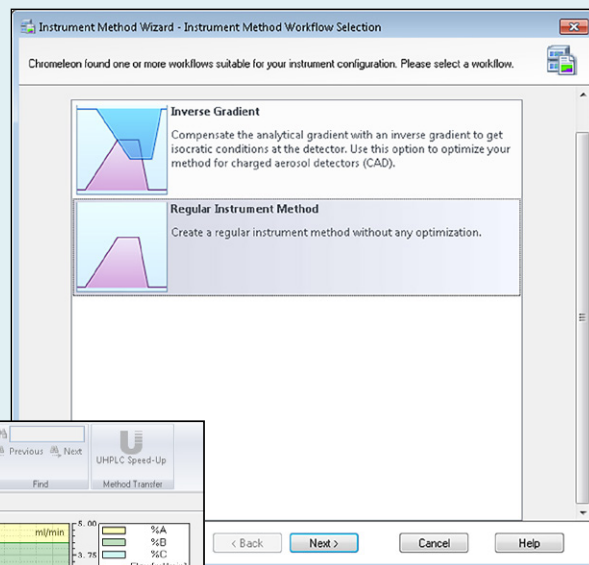

Chromeleon CDS guides users through the implementation of an inverse gradient method with automatic system volume considerations and gradient formation

# Separate your science from the status quo

As a trusted chromatography provider for more than three decades, we are proud to offer unique and highly productive solutions for your future-proof and forward-looking investment. Everything you need is within easy reach to boost the overall productivity of your laboratory.

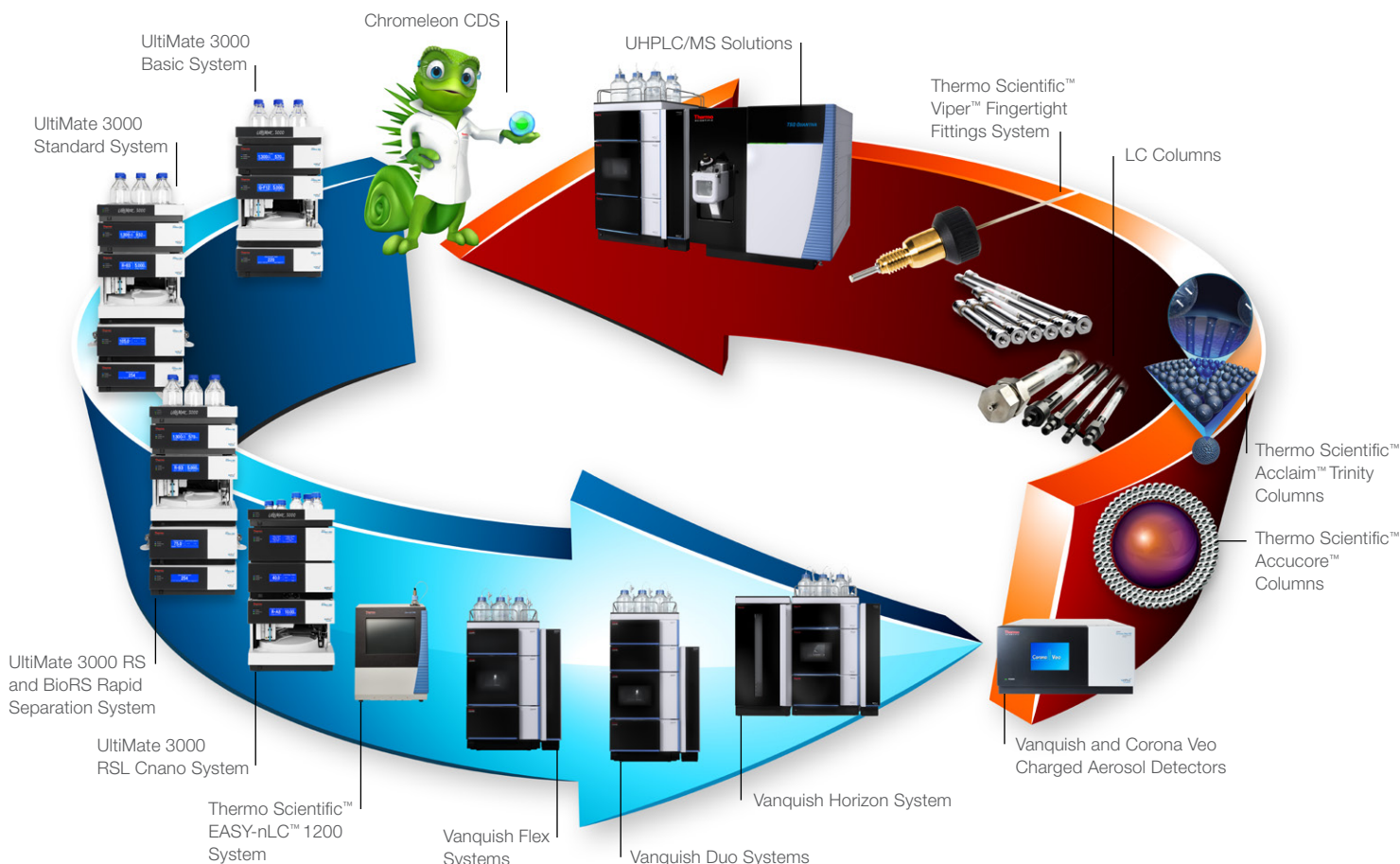

Find out more about CAD and many other applications in the Thermo Scientific™ AppsLab Library of Analytical Applications and see how the combination of Thermo Scientific HPLC and UHPLC systems using CAD with the Chromeleon Chromatography data system (CDS) is delivering productivity gains.



AppsLab Library of Analytical Application

[LEARN MORE ABOUT APPSLAB LIBRARY](#)

Find out more at [thermofisher.com/CAD](http://thermofisher.com/CAD)